

Series HD Hydraulic Dock Leveler

Structural Features*

- High-strength, 4-way safety tread plate deck and lip assembly; 55,000 psi yield.
- Full-width, self-cleaning, heavy-wall hinge tube; 70,000 psi yield.
- Gussets on lip and headboard hinge maximize support.
- Deep, 8" high, one-piece headboard with bridged gaps; radii on all inside corners for maximum strength; 50,000 psi yield.
- Structural, precision-formed "C" beams; 65,000 psi yield. Specially designed beams allow Pentalift to create and build the deck support with optimal strength-to-weight ratio for a dock leveler. Utilizing 10 beams assures an even load distribution and maximum deck support.
- Central deck beam for added support of three-wheeled vehicles.
- Full-width, structural channel tailboard and one-piece, full-width rear hinge complete with heavy steel gussets. Pentalift's unique, welded assembly provides a box section (Fig. 5) for superior support.
- Rear frame assembly features five vertical structural members with eight points of even support for the full-width rear hinge.
- Heavy-duty front frame provides full-width, cross-traffic support and superior building aesthetics.
- Night lock prevents unauthorized entry when overhead door is locked on top of dock leveler.



Fig. 5

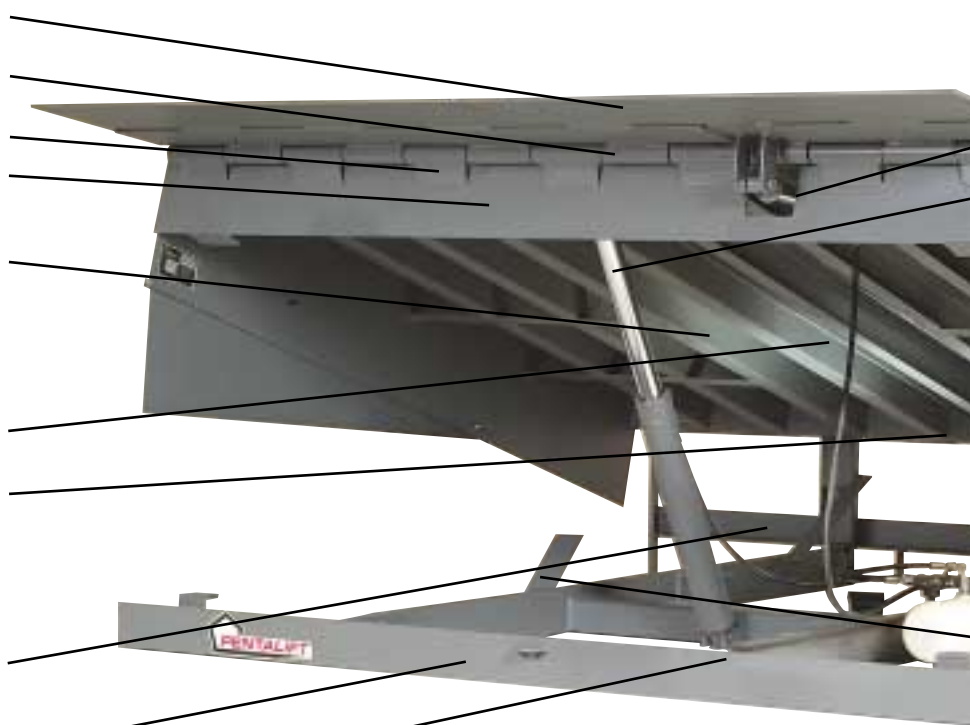

*Model HD6835

Lift Cylinder Placement

Fallsafe is a situation in which a hydraulic velocity fuse locks the cylinder and deck in position should a truck prematurely depart while a forklift is still positioned on the leveler.

Master Control Panels

Master Control Panels are available to suit various applications and combinations of dock equipment. Master control panels are used to simplify and harmonize the operation of the loading dock equipment, increase safety, reduce field-wiring costs and conserve wall space at the loading dock. The dock equipment that is typically interlocked is any combination of: hydraulic dock leveler, vehicle restraint and safety light system, overhead door and/or inflatable dock shelter.



Fig. 7



Fig. 8

Other Manufacturers

Other manufacturers position their lift cylinder as illustrated above (Fig. 8). During a fallsafe condition, with the front tires of the forklift past the upper cylinder support point, a dangerous "teeter-totter" situation occurs. The back of the deck is forced upwards and out of the rear frame. In addition, the positioning creates a mechanical disadvantage during fallsafe (1" stroke = 4" deck drop).

Other cylinders, with the chrome plated piston facing downward, are prone to surface damage and chipping, leading to hydraulic seal failure.



Fig. 9

Pentalift

For most effective support, Pentalift's lift cylinder is securely positioned at the junction of the deck and the structural headboard (Fig. 9). The base of the cylinder is connected to a structural cross member. During a hydraulic fallsafe situation (incorporating non-adjustable velocity fuse) the forklift will be completely supported between the cylinder position and the rear frame. All generated forces are downward, in the manner all dock levelers are designed to accept load forces.

The Pentalift lift cylinder is positioned correctly, away from debris found in the pit. Its position provides a superior mechanical advantage when raising the deck.

Operating Features

- Self-retracting, hydraulic lip cylinder is standard on all models for fully hydraulic operation.
- Top-fed, forward-positioned hydraulic lift cylinder.
- Telescopic toe protection assures total dock attendant safety. Lower section features a “bend relief” to maximize strength.
- Fixed rear hinge remains flush with the rear of the pit to eliminate potential pinch points and surface obstructions. Design allows 4” of lateral deck compensation to accommodate canted truck/trailer beds.
- Hydraulic power unit incorporates internal filtration system and 1 1/2 hp TENV motor.
- Integral, posi-lock maintenance strut supports both deck and lip assembly during maintenance and service.

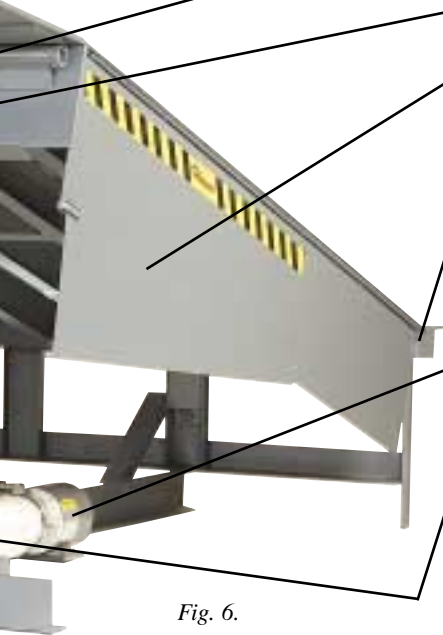

Fig. 6.

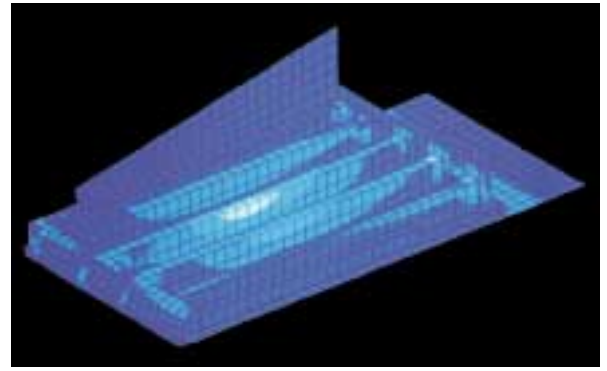

Fig. 10

Balanced Design for Structural Harmony

Other dock leveler manufacturers boast of individual components as though they were unrelated to each other in strength. Little thought is given to the overall structural balance of the combined load-bearing components.

Many dock leveler manufacturers fail to realize that, in many respects, the combination of structural components is similar to a chain and a chain is only as strong as its weakest link.

Through the use of state-of-the-art finite element analysis software, Pentlift components are designed and sized to maintain structural balance and harmony throughout, assuring maximum dock leveler life by eliminating any weak links.

Self-Retracting Lip

A self-retracting lip is an important safety and performance feature. The *Pentalogic* hydraulic manifold facilitates the self-retracting lip on Pentlift “HD” Series dock levelers.



Fig. 11

Pentalogic Hydraulic Manifold

Operating every hydraulic function with only two moving parts, the *Pentalogic* hydraulic manifold revolutionized dock leveler hydraulic control circuitry. Conventional hydraulic dock leveler control valve circuitry is comprised of several individual function valve assemblies. These assemblies are constructed from many sub components, increasing the potential of hydraulic component failure and oil leaks. Utilizing only two moving components, the non-adjustable *Pentalogic* hydraulic manifold eliminates all concerns related to on-site adjustment, oil leaks or hydraulic component failure.

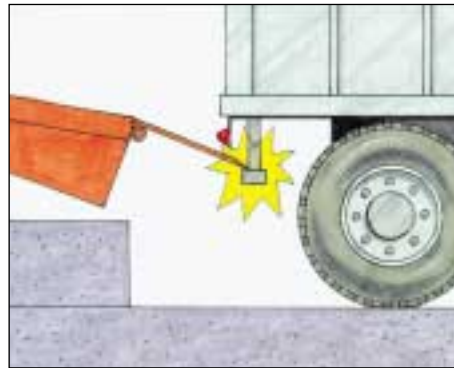

Fig. 12

Conventional hydraulic dock levelers, yieldable lip circuits utilize an “in line” pressure relief valve, maintaining the lip in the extended position. Once a vehicle departs, the deck lowers with the lip remaining in the extended position. The next incoming vehicle will impact the extended lip and any excessive force will push the lip assembly back into the pendant position. In addition, a conventional hydraulic circuit can cause the lip to get “caught on” a portion of the incoming truck (Fig. 12), resulting in extensive damage to the vehicle, dock leveler and cargo.

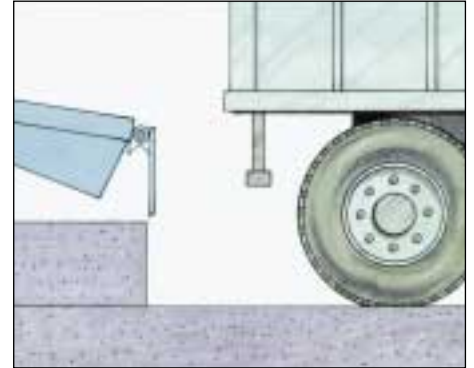

Fig. 13

On truck departure, the *Pentalogic* hydraulic manifold allows the lip assembly to gently retract into the pendant position prior to the arrival of the next incoming vehicle (Fig. 13). The *Pentalogic* hydraulic manifold assures that the lip is always pendant behind the protective bumpers. Units equipped with automatic return-to-stored-position, work in conjunction with the self-retracting lip (eliminating false signals common with other makes), to return the deck to the safe, stored position.