

ROLLING SERVICE DOORS

800C

WAYNE-DALTON COMMERCIAL DOOR SYSTEMS

THERMOTITE® 800C SERIES ROLLING SERVICE DOORS

INSULATED ROLLING STEEL DOORS CUT YOUR TOTAL ENERGY COST

The Wayne-Dalton 800C Series rolling service door is designed to meet the tough requirements of virtually any commercial or industrial application with the added advantage of energy efficiency. The 800 series offers flexibility in substrate materials with choices of galvanized or prime steel, stainless steel, or aluminum.

Color options range from our standard five factory finish colors to a full range of 180 RAL powder coat choices. Polyurethane insulation in each slat promotes energy savings and building comfort.



COMMERCIAL DOORS & OPERATORS

- SIZES UP TO 42' WIDE AND 40' HIGH
- INSULATION R-VALUE = 6.7
- MAX STEEL GAUGE = 18
- FLAT 3" SLAT
- WINDLOAD UP TO 55 PSF

ROLLING SERVICE DOORS

800C SERIES

Popular in both interior and exterior applications, the Wayne-Dalton 800C Series insulated rolling service door features a galvanized, pre-painted curtain of minimum 22-gauge steel. 800C Series doors are wind load rated at 20 PSF. An optional wind load rating of up to 55 PSF is available to cover your Florida and Dade County windload requirements.

Materials & Construction

Wayne-Dalton's 800C Series rolling doors are composed of flat slats that provide a natural water-shed, helping to reduce corrosion. The slats are designed with free-acting interlocking joints that permit easy articulation when the door coils.

The 800C Series features a strong double-angle bottom bar that reinforces the lower edge of the curtain against wind pressure and permits varied lock, astragal, and safety edge options. This bottom bar is designed for easy installation and does not require fasteners protruding into the guide openings, so the bottom bar does not interfere with door operation.

Counterbalance assembly consists of a spring barrel which serves as load-carrying beam. It encases the counterbalance mechanism and provides the axis around which the curtain coils. (Deflection is limited to 0.033" per lineal foot of span.) If required, barrel rings of malleable iron or stamped steel may be provided to assure proper counterbalance. Oil-tempered, torsion-type counterbalance springs are wound from heat-treated steel, providing accuracy in balancing the door. Barrel plugs connect ends of springs to barrel and tension rod. Tension rod of steel shafting holds fixed ends of springs and carries torsion load of spring counterbalance.

Spring tension adjusting wheel is normally mounted outside the bracket on end of tension rod. Inside adjusting wheel for tight side-room applications is available in limited sizes.

The hood cover encloses the curtain coil and counterbalance mechanism. Slat hoods are available on blue, brown, beige, and white doors.

Available Options

- Vision Slats/Panels
- Safety Edges
- Drop Stop Device
- Exhaust Ports
- Sloping Bottom Bars
- Powder Coated
- Motor Operators
- Cable Reels
- Mullions
- Thru-Wall Operation
- Stainless Steel or Aluminum Finishes



Slat Profile

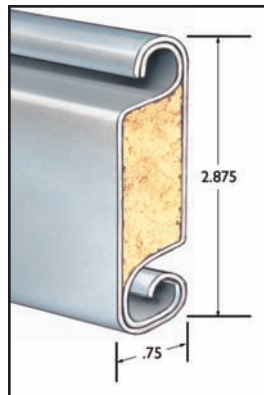

Standard Weatherseal Applications

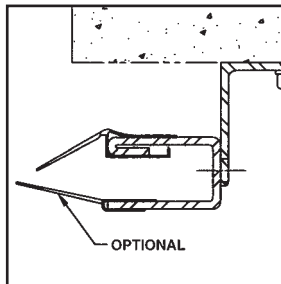

To close space between curtain and guides at jambs, flexible strip on guides contacts flat surface of curtain.

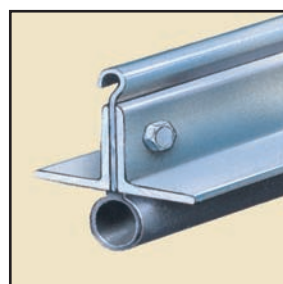

Bottom bar with weatherseal

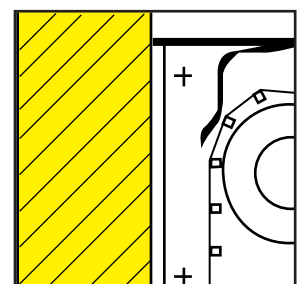

To reduce air infiltration at top of door, hood baffle attached to hood extends full width of door. Optional lintel weatherstripping will further reduce air passage when attached to the header.

ROLLING SERVICE DOORS

800C SERIES

MANUAL OPERATION

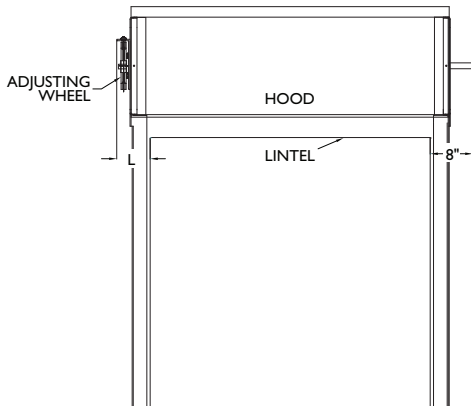

ELEVATION

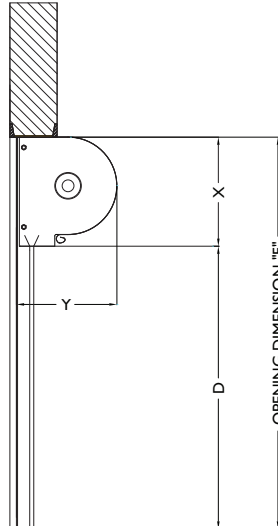

SECTION (UNDER LINTEL)

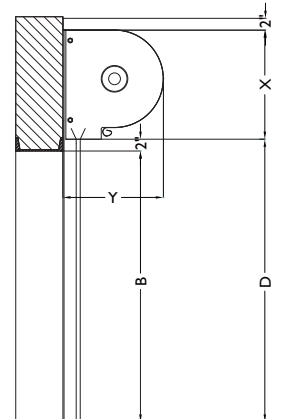

SECTION

BRACKET MOUNTED POWER UNIT

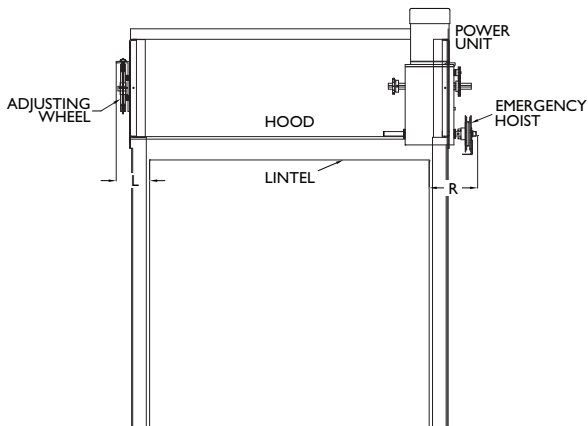

ELEVATION

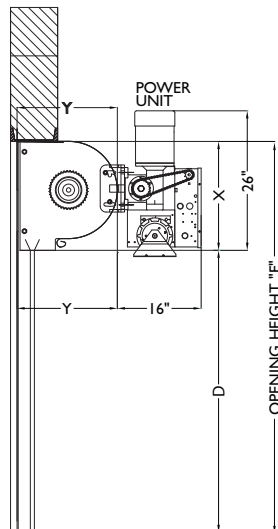

SECTION (UNDER LINTEL)

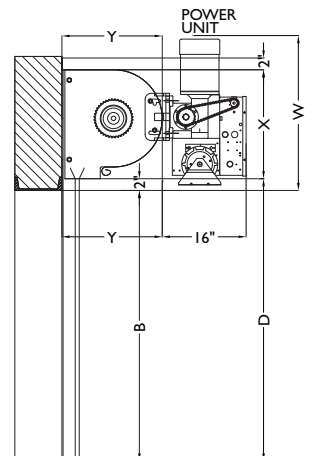

SECTION

ANGLE OR ROLLED GUIDES - FACE MOUNTED TO MASONRY



ANGLE OR ROLLED GUIDES - FACE MOUNTED TO STEEL

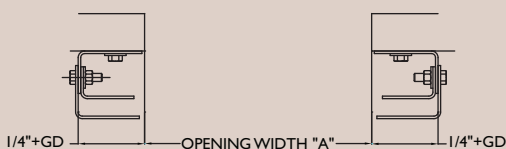

ANGLE GUIDES - MOUNTED BETWEEN JAMBS

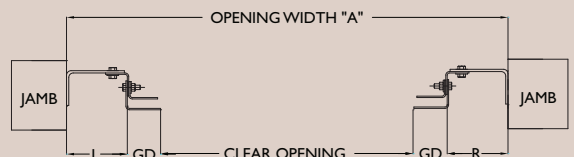

ROLLED GUIDES - MOUNTED BETWEEN JAMBS

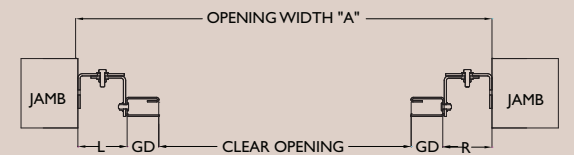

800C Series Door	
GD	WIDTH
2-3/4"	TO 28'0" WIDTH
3-1/4"	TO 30'0" WIDTH

ROLLING SERVICE DOORS

800C SERIES

CHAIN HOIST OPERATION

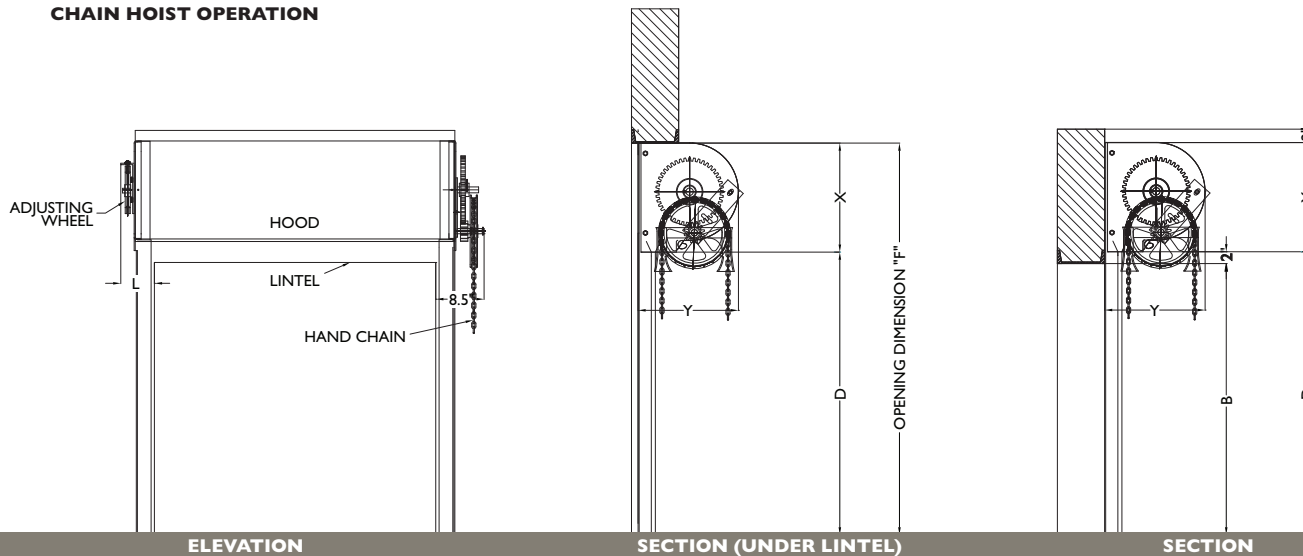

WALL MOUNTED POWER UNIT

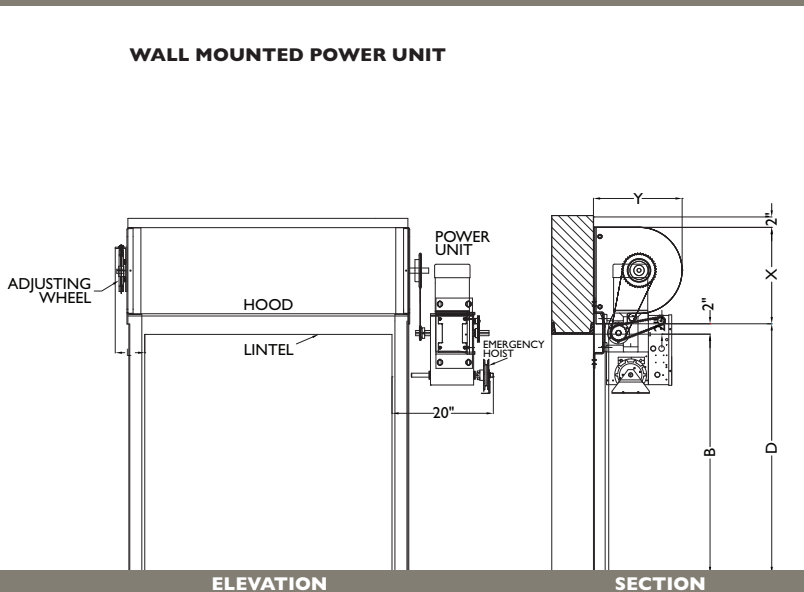

THRU-WALL MOUNTED POWER UNIT

Note: 20" sideroom required on opposite door side for power unit

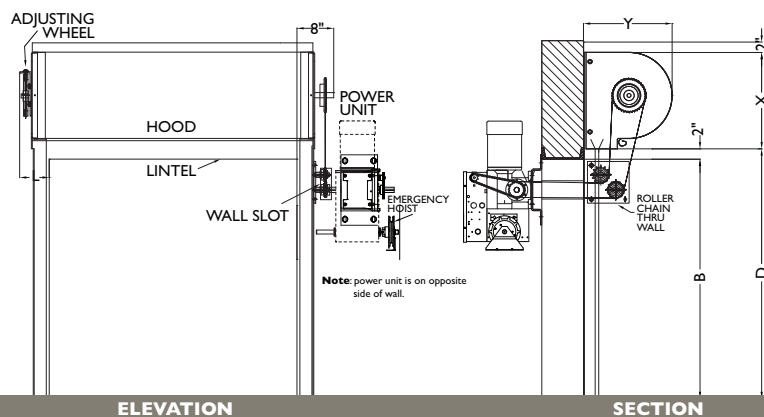

ROLLING SERVICE DOORS

800C SERIES

General Operating Clearances 800C Series Doors (3" slats)

WIDTH A	OPENING HEIGHT																								
	10'0"			10'0" TO 11'0"			11'0" TO 13'6"			13'6" TO 17'6"			13'6" TO 19'0"			17'6" TO 22'0"			19'0" TO 22'0"						
	X & Y	R	L	X & Y	R	L	X & Y	R	L	X & Y	R	L	X & Y	R	L	X & Y	R	L	X & Y	R	L				
FACE MOUNTING																									
CHAIN HOIST OPERATED																									
TO 24'0"	18-1/2"	9 1/8"	7 1/8"	20"	9 1/8"	7 1/8"	22"	9 1/8"	7 1/8"																
TO 16'0"										24"	9 1/8"	7 1/8"				26"	9 1/8"	7 1/8"							
16'0" TO 24'0"													24"	9 1/8"	7 1/8"				26"	9 1/8"	7 1/8"				
MOTOR OPERATED																									
TO 24'0"	18-1/2"	9 1/8"	7 1/8"	20"	9 1/8"	7 1/8"	22"	9 1/8"	7 1/8"																
TO 16'0"										24"	9 1/8"	7 1/8"				26"	9 1/8"	7 1/8"							
16'0" TO 24'0"													24"	9 1/8"	7 1/8"				26"	9 1/8"	7 1/8"				

NOTE: Dimensions are for general reference only and not for construction purposes.



COMMERCIAL DOORS & OPERATORS

THERMOTITE® 800C SERIES

Note to specifiers: Words in brackets indicate frequently specified and highly recommended options.

PART I – GENERAL

1.01 Work Included

- A. The opening will be equipped with Wayne-Dalton 800C Series rolling doors.

1.02 Related Work

- A. Opening preparation, miscellaneous or structural metal work, access panels, finish or field painting, field electrical wiring, wire, conduit, fuses, and disconnect switches are in the Scope of Work of other divisions or trades.

1.03 Reference Standards

- A. **ANSI/DASMA 203** – American National Standards Institute Specifications for non-rated fire rolling doors published by Door & Access Systems Manufacturers Association International.
- B. **ASTM A123** – Zinc [hot-dipped galvanized] coatings on iron and steel products.
- C. **ASTM A229** – Steel wire, oil-tempered for mechanical springs.
- D. **ASTM A-653-94** – Steel sheet, zinc-coated [galvanized] by the hot-dipped process, commercial quality.
- E. **ASTM E330** – Structural performance of exterior windows, curtain walls, and doors by uniform static air pressure difference.
- F. **ASTM E413-87** – Sound transmission class acoustical performance value = 22.

1.04 Quality Assurance

- A. Rolling doors and all accessories and components required for complete and secure installations shall be manufactured as a system from one manufacturer.

1.05 Systems Description

- A. Rolling Door: Type: **Model 800C**
- B. Mounting: [steel] [wood] [masonry] jambs
- C. Operation: [manual push-up] [crank] [chain hoist] [motor] [motor with chain hoist]
- D. Material: Galvanized steel with polyester finish paint

1.06 Submittals

- A. Shop Drawings: Clearly indicate the following:
 1. Design and installation details to withstand standard windload.
 2. All details required for complete operation and installation.
 3. Hardware locations.
 4. Type of metal and finish for door sections.
 5. Finish for miscellaneous components and accessories.
- B. Product Data: Indicating manufacturer's product data, and installation instructions.

1.07 Delivery, Handling, Storage

- A. Deliver products in manufacturer's original containers, dry, undamaged, seals and labels intact.
- B. Store and protect products in accordance with manufacturer's recommendations.

1.08 Warranty

- A. Standard manufacturer's one year warranty against defects in material and workmanship.

PART II – PRODUCTS

2.01 Curtain

- A. Curtain will be composed of interlocking #14 flat slats [22, 20, 18 gauge galvanized steel] [16 B&S aluminum] [22, 20 stainless steel] slats with [24 gauge] [22 gauge B&S aluminum] back slats, roll-formed per ASTM standards. The area between the #14 exterior slat and the back slat will be filled by polyurethane insulation, R-value of 6.7 (U = 0.15). Curtain designed to withstand a 20 PSF windload. Ends of alternate/continuous slats will be fitted with metal endlocks/windlocks.
- B. Bottom Bar will consist of two equal steel [stainless steel] [aluminum] angles, .121" minimum thickness, to stiffen curtain, with astragal. When required for additional security, provide [slide bolts] [cylinder locks] on the bottom bar operable from [coil side] [both sides].

2.02 Guides

- A. Guides will be roll-formed steel channel bolted to angle or structural grade, three angle assembly of steel [stainless steel] [aluminum] to form a slot of sufficient depth to retain curtains in guides to achieve 20 PSF windload standard. Guides may be provided with integral windlock bars and removable bottom bar stops.

2.03 Brackets

- A. Brackets will be of 3/16" [1/4"] minimum thick steel plates, with permanently sealed ball bearings. Designed to enclose ends of coil and provide support for counterbalance pipe at each end.

2.04 Counterbalance

- A. Curtain to be coiled on a pipe of sufficient size to carry door load with deflection not to exceed .033" per foot of door span and to be correctly balanced by helical springs, oil tempered torsion type. Cast iron barrel plugs will be used to anchor springs to tension shaft and pipe.

2.05 Hood

- A. Hood will be minimum 24-gauge [aluminum, 22 gauge B&S] [galvanized] [stainless steel] sheet metal, flanged at top for attachment to header and flanged at bottom to provide longitudinal stiffness. Hood will enclose curtain coil and counterbalance mechanism. A flexible hood baffle is included.

2.06 Finish

- A. Shop coat of rust inhibitive primer on non-galvanized surfaces and operating mechanisms. Guides and bracket plates will be coated with a flat black prime paint. Aluminum finish to be [mill] [204R1 clear anodized] [bronze anodized]. Stainless steel finish available. Curtain color will be [white] [blue] [gray] [beige] [brown] (white, blue, beige, brown only available as 22 gauge). Powder coating is available in 180 colors.

2.07 Operation

- A. Door will be operated by means of [manual, lift-up] [chain hoist with gear drive reduction] [awning crank] [wall crank box] [motor operation]. Optional [electrical] [pneumatic] sensing edge to be attached to

bottom bar to [stop and reverse] the door when it contacts an object during the closing cycle.

2.08 Weatherstripping

- A. Doors will include bottom astragal, surface guide weatherstrip, and internal hood baffle weatherstrip. Optional lintel brush weatherstrip available.

2.09 Locking

- A. [Manual lift-up doors will have interior slide-bolts suitable for padlocks by others.] [Chain-hoist door will have chain keepers suitable for padlocks by others.] [Electric-motor operation doors will lock through the operator gearing.] [Cylinder locks can be provided with the doors.]

Note: When specifying locks on electric-motor operated doors, electric interlocks should also be specified to prevent operation when lock bolts are engaged in the guides, thus preventing damage to the curtain and/or operator.

2.10 Windload

- A. Windload – minimum 20 psf per DASMA 102-2003 and as required by local codes.

PART III – EXECUTION

3.01 Installation

- A. General:
 1. Install doors in accordance with manufacturer's instructions and standards. Installation shall be by an authorized Wayne-Dalton representative.
 2. Verify that existing conditions are ready to receive rolling door work.
 3. Beginning of rolling door work means acceptance of existing conditions.
- B. Install door complete with necessary hardware, jamb and head mold strips, anchors, inserts, hangers, and equipment supports in accordance with final shop drawings, manufacturer's instructions, and as specified herein.
- C. Fit, align and adjust rolling door assemblies level and plumb for smooth operation.
- D. Upon completion of final installation, lubricate, test and adjust doors to operate easily, free from warp, twist or distortion and fitting for entire perimeter.

Note: Architect may consider providing a schedule when more than one rolling door or opening type is required.

Because of continuing product improvements, we reserve the right to change the product specifications and designs without prior notice.

Distributed By:



COMMERCIAL DOORS & OPERATORS

For technical information, visit:

www.wayne-dalton.com/commercial

© 2008 Wayne-Dalton Corp. • One Door Drive • Mt. Hope, Ohio 44660 • 800-255-3046
Mt. Hope, OH • Dalton, OH • Trail, OH • Pensacola, FL • Portland, OR

Printed in U.S.A.
Item #333068 Revised 4/2008